

This Page Is Inserted by IFW Operations
and is not a part of the Official Record

BEST AVAILABLE IMAGES

Defective images within this document are accurate representations of the original documents submitted by the applicant.

Defects in the images may include (but are not limited to):

- BLACK BORDERS
- TEXT CUT OFF AT TOP, BOTTOM OR SIDES
- FADED TEXT
- ILLEGIBLE TEXT
- SKEWED/SLANTED IMAGES
- COLORED PHOTOS
- BLACK OR VERY BLACK AND WHITE DARK PHOTOS
- GRAY SCALE DOCUMENTS

IMAGES ARE BEST AVAILABLE COPY.

**As rescanning documents *will not* correct images,
please do not report the images to the
Image Problem Mailbox.**

PATENT SPECIFICATION

(11)

1 469 363

1 469 363

- (21) Application No. 2798/75 (22) Filed 22 Jan. 1975
(31) Convention Application No. 440 071 (32) Filed 6 Feb. 1974 in
(33) United States of America (US)
(44) Complete Specification published 6 April 1977
(51) INT. CL.² B62M 1/04
B62K 21/00//F16H 31/00
(52) Index at acceptance
B7E 41 58 67
F2Q 1A1



(54) A RIDER PROPELLED CYCLE

SCIENCE REFERENCE LIBRARY

(71) I. ROBERT LEE SINK, a citizen of the United States of America, of 10 North Edmondson, Indianapolis, Indiana, United States of America, do hereby declare the invention for which I pray that a patent may be granted to me and the method by which it is to be performed to be particularly described in and by the following statement:—

10 This invention relates to a cycle, which in one embodiment to be described herein is powered by the united effort of the arm, leg, and trunk muscles of the operator.

15 The prior art encompasses a wide variety of man-powered bicycles, tricycles, and the like. While man-powered cycles do provide a means of transportation, they also serve to exercise a variety of the operator's muscles. The majority of man-powered

20 cycles now available are designed to exercise either the operator's shoulders and arms, or his legs. The most common example of a leg-powered cycle is the conventional pedal-operated bicycle, while a

25 typical hand-powered device normally includes a crank which is manually rotated by the operator to provide the required driving force. Such a hand-powered cycle is shown, for example, by Clark. U.S. Patent No. 506,626.

30 These foot or hand-powered cycles only provide adequate exercise for one portion of the operator's anatomy. An additional drawback encountered with the hand-

35 powered cycles is that they typically require separate and independent structures to steer the cycle, making it difficult to safely operate the driving and steering mechanisms simultaneously.

40 A number of cycles have been developed which combine the driving and steering mechanisms to permit the cycle to be more easily controlled. See, for example, Clark. U.S. Patent No. 516,786. This cycle utilizes

45 a hand-operated driving lever which is

50 moved back and forth about a pivot to provide force for the cycle. The driving lever is also rotatable about its own axis to provide turning motion to the steering wheel of the cycle. This type of cycle is limited to driving levers disposed wholly above the steering wheel of the cycle and, if the operator's feet are to be used to help oscillate the lever, his feet must also be positioned above the steering wheel. This places the operator in an awkward position with his hands and feet high above ground and so makes control of the cycle difficult. Moreover, if the lever is oscillated and rotated simultaneously to drive the cycle while turning, the lever necessarily moves back and forth in a crossing motion through the longitudinal plane of the cycle. Such crossing motion continually shifts the weight of the operator, making safe control of the cycle extremely difficult.

65 The present invention provides a cycle, comprising a frame having a seat mounted thereon, rotatably mounted front and rear wheels, said front wheel being carried by a member pivotally mounted to said frame to permit steering of the cycle, an upwardly extending driving column pivotally mounted intermediate its ends to said frame for oscillatory movement in a plane parallel to the plane of said frame, a one-way clutch rotatably mounted on said frame, said clutch having a first part and a second part, said first part drivingly engaging said second part upon rotation of said first part in a first direction relative to said second part to drive said second part in the same direction, said first and second clutch parts being in slipping engagement in the event of rotation of said first part relative to said second part in the opposite direction to said first direction. A driving link pivotally coupled to said column and to said first clutch part to rotate said first clutch part in said first

70 75 80 85 90

direction relative to the second clutch part in response to pivoting movement of said column in one direction about its pivotal mounting to said frame; means coupling
 5 said second clutch part to said rear wheel to transmit rotational motion of said second clutch part to said rear wheel, a steering rod rotatably mounted on said driving column for rotation about its own axis and
 10 for oscillation with said column, the axis of said steering rod being parallel to said column, a handle bar rotatably mounted to the upper end of said column and coupled to said steering rod for oscillating
 15 said column and for rotating said rod in response, respectively, to oscillatory and rotary forces applied thereto, a universal joint at the lower end of said steering rod and disposed substantially on the oscillatory
 20 axis of said column, and means coupling said universal joint to said member carrying the front wheel to turn said front wheel in response to rotation of said steering rod. Preferably a foot-rest is mounted on
 25 the driving column so that the latter is both hand and foot-operated, to provide rigorous exercise for various portions of the operator's anatomy, and permitting the operator's feet to be disposed in a stable
 30 position near the ground at all times. Furthermore, the cycle can be steered as the driving column is simultaneously and safely oscillated since the oscillations are always in the front-to-rear plane of the
 35 cycle.

When the driving column is held stationary for coasting or is not moved in the proper direction, the first clutch part is effectively rotating in a reverse direction
 40 relative to the second clutch part. The slipping engagement between the two clutch parts permit the clutch parts to freely slip while still maintaining a small drag force. The drag force tends to carry the first
 45 clutch part in a forward direction to eliminate dead center linkage configurations, in the embodiment to be described, and further tends to move the driving column in the direction necessary to obtain
 50 full driving engagement between the first and second clutch parts. This tendency of movement by driving column thereby serves as an indication to the operator of the direction he must move the column for
 55 a propelling stroke after coastings for a period.

An embodiment of the invention will now be described, by way of example only, with reference to the accompanying drawings, in
 60 which:

Fig. 1 is a side elevation view of a cycle embodying the invention;

Fig. 2 is a sectional view taken along the line 2-2 of Fig. 1

65 Fig. 3 is a sectional view taken along the

line 3-3 of Fig. 1;

Fig. 4 is a sectional view taken along the line 4-4 of Fig. 1

Fig. 5 is a cross-sectional end view of a one-way clutch of the cycle; 70

Fig. 6 is a side view, partially in section, of the clutch shown in Fig. 5;

Fig. 7 is a top plan view of the cycle; and

Fig. 8 is a sectional view taken along the line 8-8 of Fig. 3. 75

A cycle of this invention is shown in Fig. 1 and generally comprises a frame 10 on which a rear driving wheel 12 and a front steering wheel 14 are rotatably
 80 mounted. A driving and steering assembly 16 is pivotally mounted on the frame 10 and is independently coupled to the rear wheel 12 through a one-way clutch 18, and to the front steering wheel 14 through
 85 a steering bar 20.

The frame 10 is formed of metal bicycle tubing or the like and includes a front bar 22 and a rear bar 24 integrally inter-
 90 connected by a sloping center bar 26 on which the driving and steering assembly is mounted by a clamping block 27 which carries a pivot for the assembly. The front bar 22 is generally horizontal and is disposed above and to the rear of the front
 95 wheel 14. A front wheel fork 28 is pivotally coupled to the forward end of the front bar 22 by a typical bearing assembly (not shown). The front wheel 14 has an axle 30 which is rotatably mounted, as by bearings, 100 between the tines 29 of the fork 28 near the lower ends thereof as shown best in Fig. 3.

The rear bar 24 of the cycle frame 10 is also generally horizontal but is disposed
 105 below and to the rear of the front bar 22. The rearward end 31 of the rear bar 24 is rigidly connected to a rear wheel fork 32 which extends rearwardly therefrom in the same horizontal plane as the rear bar 24. The rear driving wheel 12 has an axle 34 which is rotatably mounted, as by bearings, between the tines of the fork 32 near the rearward end thereof to permit free
 110 rotation of the wheel. 115

A seat bar 36 is rigidly mounted on the frame 10 and extends horizontally and rearwardly from the center bar 26 adjacent the junction of the latter with the front bar 22. As shown in Fig. 1, the rear portion
 120 of the seat bar 36 is supported above the rear wheel 12 by a support yoke 38 which is secured between the seat bar 36 and the rear wheel fork 32. A seat 40 is secured on the seat bar 36 as by a clamp 42 and is positioned on the bar to the rear of the driving and steering assembly 16. The position of the clamp 42 can be adjustably altered to permit the operator to selectively
 125 vary the distance between the seat 40 and 130

the driving and steering assembly 16.

As shown in Fig. 2, the driving and steering assembly 16 has a driving column 43 which is comprised of a driving yoke 44 which is pivotally mounted to the center bar 26 of the frame 10 by the pivot carried by clamping block 27. The yoke 44 is formed of a pair of generally parallel bars 48 which are maintained in spaced relation by spacers 50 that are connected between the bars 48 at their ends. The bars 48 are each coupled intermediate their ends to opposite ends of a spindle 52 which is contained in and supported by the clamping block 27.

More specifically, as best shown in Fig. 3, the clamping block 27 is comprised of two block parts 56 and 58, each having a semi-circular section slot 57 and 59 therein, for mutually receiving the center bar 26 of the frame 10 at a point intermediate the ends of the center bar. Bolts 62 are used to tightly clamp the block parts 56 and 58 together. The spindle 52 is carried in the first block part 56 of the block 27 and is free to rotate about its axis with respect to the block 27. The spindle 52 is orthogonally disposed to the frame 10, thereby permitting the yoke bars 48 to be freely oscillated about a horizontal axis and in close parallel relationship to the vertical plane containing the front, center, and seat bars 22, 26, and 36. The amplitude of the preferred forward and rearward oscillation of the yoke bars 48 is shown by dotted line positions 61 and 63 in Fig. 1.

A horizontally disposed handle bar 64 is secured to a stem 66 which is rotatably mounted in the upper yoke bar spacer 50 to permit free rotation of the handle bar 64 with respect to the driving yoke 44 for reasons which will hereafter become more apparent. Conveniently, soft rubber hand grips 68 or the like are mounted over each end of the handle bar 64.

Footrests 70 are mounted at the lower ends of the yoke bars 48 and extend outwardly from each side of the driving yoke 44 in the general plane of the yoke. If desired, the footrests 70 and the lower spacer 50 can be unitarily formed of a single metal bar which is fixed to the bottom ends of the yoke bars and can be adjusted up and down for rider comfort and reach.

The handle bar 64 and the footrests 70 are provided to apply oscillatory movements to the driving column 43 about its axis and in the plane of the frame 10. By grasping the handle bar 64 and by engaging the footrests 70, an operator can, with a combined pushing and pulling action of his arms, legs, and trunk muscles, move the column 43 back and forth.

As shown in Fig. 1, a driving link 72 is pivotally coupled at one end of the yoke

bars 48 near the lower end of the driving column 43. The opposite end of the driving link 72 is pivotally coupled to one end of a crank link 74 which is fixedly mounted to the one-way clutch 18. The oscillatory movement of the driving column 43 is transmitted by the driving link 72 and the crank link 74 to the clutch 18 which converts the back and forth motion of the column into rotational motion. The relative lengths of the driving link 72 and the crank link 74 affect the stroke distance of the oscillatory movement of the yoke 44. Desirably, the link lengths are chosen so that neither link comes unduly close to the ground and so that the driving yoke 44 can be oscillated through an angle of approximately 30° to either side of the vertical. Also, if desired the crank link 74 can have a series of holes 84 spaced along its length to which the driving link can be selectively coupled to alter the driving torque required to rotate the clutch 18.

The one-way clutch 18 generally comprises a clutch plate 76 and a clutch housing 78. As shown in Figs. 4-6, both the clutch plate 76 and the clutch housing 78 are rotatably mounted on a spindle 80 which is journaled in suitable bearings 82 mounted on the rear bar 24 of the frame 10. The plate 76 and housing 78 are freely rotatable on the spindle 80 with respect to the frame 10, and are retained on said spindle by a hub 83. The crank link 74 is fixedly coupled to the outside face of the clutch plate 76 to transmit the oscillatory motion of the driving yoke 44 to the plate. Pawls 86 are mounted on the inside face of the clutch plate 76 and are adapted to frictionally engage an inner drum face 94 of the clutch housing to drive the housing 78 along with the plate 76 in a first direction of rotation of plate 76.

More specifically, and as shown in Fig. 6, three generally L-shaped pawls 86 are pivotally mounted on the inside face of the clutch plate 76 by pins 88 extending through the radially inward portions of the pawls. The pawls 86 each have smooth rounded corners, and are disposed in equally spaced arcuate relation about the clutch plate 76. The foot portion 90 of each pawl 86 is generally rounded to correspond to the circular inner drum face 94 formed on the inside face of the clutch housing 78. A suitable friction facing 92 is bonded to the drum contacting surface of each foot 90 to enhance frictional engagement between the pawls 86 and the drum face 94.

Clockwise rotation as viewed in Figure 6, of the clutch plate 76 by the driving link 72 is effective to cause full, immediate driving engagement between the pawl feet 90 and the clutch housing drum face 94

70

75

80

85

90

95

100

105

110

115

120

125

130

which accordingly drives the housing. If, on the other hand, the driving column 43 is held stationary or is oscillated so as to cause a counterclockwise rotation of the clutch plate 76, the full driving engagement of the pawl feet 90 is eliminated. However, springs 91 are coupled between the foot 90 of each pawl 86 and respective flanges 93 protruding from the inner face of the clutch plate 76. Each spring 91 is in a partially compressed state to thereby urge its associated pawl 86 about its respective pivot pin 88 and into continual, slipping engagement with the drum face 94 of the clutch housing 78 when the clutch plate is held stationary or is rotated in a counterclockwise direction. The slipping engagement permits the clutch plate 76 to freewheel relative to the housing 78 in the counterclockwise direction.

As previously mentioned, when the clutch plate 76 is driven in a clockwise direction, the pawls 86 engage the drum face 94 of the clutch housing 78 to also drive the clutch housing 78 in a clockwise direction. A large sprocket wheel 98 is fixedly mounted as by bolts 99 to the outside face of the clutch housing 78, and rotates in a clockwise direction whenever the clutch housing is so driven. As shown best in Fig. 1, a small sprocket wheel 100 is coupled to the rear axle 34 of the cycle, and rotational motion of the large sprocket wheel 98 is transmitted to the small sprocket wheel 100 by a bicycle chain 102 interconnecting the two sprocket wheels. The rear wheel 12 of the cycle is thereby driven in a clockwise, or forward, direction whenever the clutch housing 78 is similarly driven.

During operation, the cycle is propelled as the operator utilizes his arm, leg, and trunk muscles to push and pull the driving yoke 44 through an oscillatory motion about the axis of the spindle 52. As previously described, this oscillatory motion is transmitted through the driving link 72 to the clutch plate 76 to thereby rotationally drive the clutch plate. Whether the clutch plate 76 is initially driven in a clockwise or a counterclockwise direction depends upon the direction in which the driving yoke 44 is first moved. For example, if the yoke 44 is inadvertently moved initially in a direction to cause counterclockwise rotation, and thus freewheeling, of the clutch plate 76, then the operator can correct the problem simply by reversing the direction of yoke movement. This causes the links 72 and 74 to reverse the direction of rotation of the clutch plate to drive the cycle. Whenever, at anytime during operation, the direction of yoke movement is reversed in the middle of a stroke, the direction of clutch plate rotation will be reversed. That is, the operator must move the yoke com-

pletely to the end of each stroke, or the direction of rotation of the clutch plate will be reversed. Therefore, as the cycle is ridden, power stroking with the yoke 44 can be started and stopped as desired, but to resume power stroking the operator must move the yoke in the correct direction to properly rotate the clutch plate. If he moves the yoke in the incorrect direction, the clutch will simply freewheel and indicate to the operator that he must reverse yoke movement to again propel the cycle.

Whenever the cycle is moving but the operator has temporarily stopped power stroking in order to coast, the clutch housing 78 will continue to rotate along with the rear wheel 12. Since the yoke 44 is being held stationary by the operator, the clutch plate 76 will also be maintained in a stationary state. In this situation, the clutch plate 76 kinematically experiences a counterclockwise rotation with respect to the clutch housing 78, and therefore the clutch will override or freewheel as previously described during coasting. The action of the springs 91 on the pawls 86, however, serves to maintain the pawls 86 in at least a slipping state of engagement with the drum face 94 of the clutch housing 78 at all times, regardless of rotational direction. Because of this slipping engagement, the motion of the rotating clutch housing 78 during coasting creates a dragging force on the clutch plate 76 which causes the plate 76 to rotate slowly and the yoke 44 to continue moving slowly unless the operator holds the yoke 44 stationary. In this manner, the dragging force serves to gently pull on the yoke 44 to indicate to the operator the proper direction the yoke should be moved to continue power stroking.

The dragging force also serves to carry the driving link 72 and the crank link 74 past the 0° and 180° positions where they might otherwise deadlock and prevent rotational driving of the clutch in any direction. For example, upon resumption of power stroking after coasting, the dragging force rotates the links 72 and 74 past a possible dead center position as soon as the operator momentarily releases the yoke 44 from a stationary position before again moving the yoke in a direction to drive the cycle. In the event that the cycle is stopped with the links 72 and 74 in a dead center position, the operator can alleviate the problem simply by manually pushing the cycle forward to start rotating the rear wheel. Such rotation imparts a dragging force on the clutch plate 76 to carry the links past dead center, as well as to gently pull the yoke 44 in the direction in which it should be moved to drive the cycle.

Steering of the cycle is accomplished 130

through linkages 103 mounted alongside the driving yoke 44. As previously mentioned with reference to Fig. 2, the handle bar 64 has a stem 66 which is rotatably secured to the top of the driving yoke 44. As shown in Figs. 2 and 7, a rotator link 104 has one end fixed to the stem 66 and extends outwardly therefrom. A second rotator link 105 is pivotally connected between the extended end of the first link 104 and an end of a third rotator link 106. The other end of the third link is fixed to the top of a steering rod 107. This linkage is effective to transmit rotation of the handle bar 64 successively through the links 104, 105, and 106 to rotate the steering rod 107. The lower end of the steering rod 107 terminates in the upper portion 109 of a universal joint 110. As shown in detail in Fig. 8, the universal joint 110 is supported in position by a bracket 112 which is secured by bolts 113 to the second part 58 of the clamping block 27. The bracket 112 serves to position the universal joint 110 substantially on the oscillatory axis of the driving column.

The lower portion 111 of the universal joint 110 extends through the bracket 112 and is fixedly coupled as by a clamping bolt 114 to a steering link 116. As shown in Fig. 3, the link 116 extends laterally outwardly from the frame and is pivotally coupled at its other end to one end of the steering bar 20. The other end of the steering bar 20 is pivotally coupled to a link 118 which is secured to one tine of the front wheel fork 28. The link 118 extends laterally outwardly from the fork 28 in general parallel relationship to the steering link 116.

The direction of movement of the cycle is controlled by the relative rotational position of the handle bar 64. When the handle bar 64 is rotated with respect to the driving yoke 44, the rotator link 104 turns along with the handle bar 64 and acts through the second and third links 105 and 106 to rotate the steering rod 107 about its own axis. The steering rod rotation is transmitted through the universal joint to the steering link 116, which, in turn, acts through the steering bar 20 and the link 118, to impart the rotational motion to the front wheel fork 28 to turn the front wheel.

The lengths of the links 104, 105, and 106 need only be sufficient to effectively transmit the rotational motion of the handle bar 64 to the steering rod 107. However, the lengths of the steering links 116 and 118 should be sufficient to maintain a degree of clearance between the bar 20 and the wheel 14 during a normal turning motion.

The steering mechanism of this cycle operates totally independently of the driving mechanism, although they are both part

of the same assembly 16. The driving yoke 44 is oscillatingly movable about the axis of the spindle 52 in the plane of the frame 10 under forces applied to the handle bar 64 and the footrests 70 by the operator. The yoke 44 cannot be rotated about its longitudinal axis nor can it be moved across or out of the plane of the frame. When the cycle is to be turned to the left or to the right, the handle bar is rotated with respect to the yoke to rotate the rod 107 which is oscillated with the yoke 44. The universal joint 110 permits the turning motion of the handle bar 64 to be transferred from the rod 107 to the steering link 116 therebelow, irrespective of the angular relationship between them. Therefore, propulsion of the cycle is accomplished solely through the oscillator of the driving yoke 44, and steering is accomplished solely through the rotational movement of the handle bar 64 relative to the yoke 44. Since the universal joint 110 is disposed substantially on the oscillatory axis of the yoke 44, the movement of either does not effect the other in any way.

Braking can be accomplished through the use of a conventional caliper-type hand brake. While such brakes are not shown in the drawings for purposes of clarity, they can be readily mounted to one or both wheels and controlled by hand grips mounted on the handle bar.

The cycle which has been described is particularly well-suited to develop muscles in arms, legs, and torso, separately or in arms, legs and torso, separately or together in varying combinations. The distance between the seat 40 and the driving assembly 16 can be easily and quickly adjusted to increase or decrease the torso involvement required to drive the cycle. Moreover, the length of the driving stroke and the torque required to drive the cycle can be selectively varied by increasing or decreasing the effective length of the crank link 74.

WHAT WE CLAIM IS:—

1. A cycle, comprising a frame having a seat mounted thereon, rotatably mounted front and rear wheels, said front wheel being carried by a member pivotally mounted to said frame to permit steering of the cycle, an upwardly extending driving column pivotally mounted intermediate its ends to said frame for oscillatory movement in a plane parallel to the plane of said frame, a one-way clutch rotatably mounted on said frame, said clutch having a first part and a second part, said first part drivingly engaging said second part upon rotation of said first part in a first direction relative to said second part to drive said second part in the same direction, said first

and second clutch parts being in slipping engagement in the event of rotation of said first part relative to said second part in the opposite direction to said first direction, a
5 driving link pivotally coupled to said column and to said first clutch part to rotate said first clutch part in said first direction relative to the second clutch part in response to pivoting movement of said
10 column in one direction about its pivotal mounting to said frame; means coupling said second clutch part to said rear wheel to transmit rotational motion of said second clutch part to said rear wheel, a steering
15 rod rotatably mounted on said driving column for rotation about its own axis and for oscillation with said column, the axis of said steering rod being parallel to said column, a handle bar rotatably mounted to
20 the upper end of said column and coupled to said steering rod for oscillating said column and for rotating said rod in response, respectively, to oscillatory and rotary forces applied thereto, a universal
25 joint at the lower end of said steering rod and disposed substantially on the oscillatory axis of said column, and means coupling said universal joint to said member carrying the front wheel to turn said front wheel in
30 response to rotation of said steering rod.

2. A cycle as set forth in claim 1, wherein a footrest is mounted on said driving column and extends outwardly therefrom.

3. A cycle as set forth in claim 1 or
35 2, wherein said seat is mounted on said frame above the level of said rear wheel and to the rear of said driving column.

4. A cycle as set forth in any preceding claim, wherein said driving link is pivotally
40 coupled to said driving column at a point disposed below the oscillatory axis of said column.

5. A cycle as set forth in any preceding claim, wherein said frame comprises a
45 generally horizontal front bar disposed above the level of said front wheel, said member carrying the front wheel comprising a steering fork pivotally coupled to the forward end of the said front bar and extending generally forwardly and downwardly
50 therefrom in the plane of the frame, a generally horizontal rear bar disposed below and to the rear of said front bar and having a second fork coupled to the rearward end thereof, extending rearwardly
55 therefrom and carrying the rear wheel, and a center bar interconnecting said front and rear bars, said driving column being pivotally mounted to said center bar intermediate the ends of that bar.

6. A cycle as set forth in claim 5, further comprising a generally horizontal seat bar extending rearwardly from said center bar to lie above said rear wheel and means
60 connected between said second fork and

said seat bar for supporting said seat bar above said rear wheel, said seat being adjustably mounted on said seat bar to the rear of said driving columns.

7. A cycle as set forth in any preceding
70 claim, wherein said driving column comprises a pair of parallel bars mounted intermediate their ends on a spindle and laterally interconnected by a plurality of
75 spacers, said spindle being mounted in a clamp, and said clamp being fixed to said frame to permit oscillation of said bars about the axis of said spindle in a plane parallel to the plane of said frame.

8. A cycle as set forth in any preceding
80 claim, wherein said first clutch part comprises a clutch plate and said second clutch part comprises a clutch housing having a drum face formed thereon, said clutch plate carrying a plurality of pawls mounted on
85 one face of said plate and operably engageable with said drum face upon rotation of said clutch plate in said first direction to cause said clutch housing to rotate in said first direction, said pawls being spring-
90 loaded so as to be in slipping engagement with said drum face when said clutch plate is stationary relative to or rotating in the opposite direction relative to said clutch housing.

9. A cycle as set forth in any preceding
95 claim, wherein said means coupling said second clutch part to said rear wheel comprises a first sprocket wheel secured to said second clutch part and rotatable therewith,
100 a second sprocket wheel secured to said rear wheel and rotatable therewith, and a sprocket chain in mesh with said first and second sprocket wheels to transmit rotational motion of one of said sprocket wheels
105 to the other of said sprocket wheels.

10. A cycle as set forth in any preceding claim, including a crank link with a plurality of holes disposed along the
110 length thereof, said crank link having one end fixedly mounted to said first clutch part, and wherein said driving link is pivotally coupled to said crank link at one of said holes.

11. A cycle as set forth in any preceding
115 claim, wherein said handle bar is coupled to said steering rod by means comprising a first link secured to said handle bar and rotatable therewith and extending radially outwardly therefrom, a second
120 link pivotally connected to said first link, and a third link secured to said steering rod and pivotally connected to said second link whereby rotation of said handle bar is transmitted through said links to rotate
125 said steering rod.

12. A cycle as set forth in any preceding claim, wherein said means coupling said universal joint to said member carrying the front wheel comprises a first steering
130

link secured to said universal joint and rotatable therewith and extending outwardly therefrom generally normal to said steering rod, a second steering link secured to one
5 side of said front wheel carrying member and disposed generally parallel to said first steering link, and a steering bar pivotally connected to said first and second steering

links.

13. A cycle substantially as herein 10 described with reference to and as shown in the accompanying drawings.

A. A. THORNTON & CO.
Northumberland House
303-306 High Holborn
London WC1V 7LE England

Printed for Her Majesty's Stationery Office by The Tweeddale Press Ltd., Berwick-upon-Tweed, 1977.
Published at the Patent Office, 25 Southampton Buildings, London, WC2A 1AY, from which copies
may be obtained.

1469363

COMPLETE SPECIFICATION

2 SHEETS

This drawing is a reproduction of the Original on a reduced scale

Sheet 1

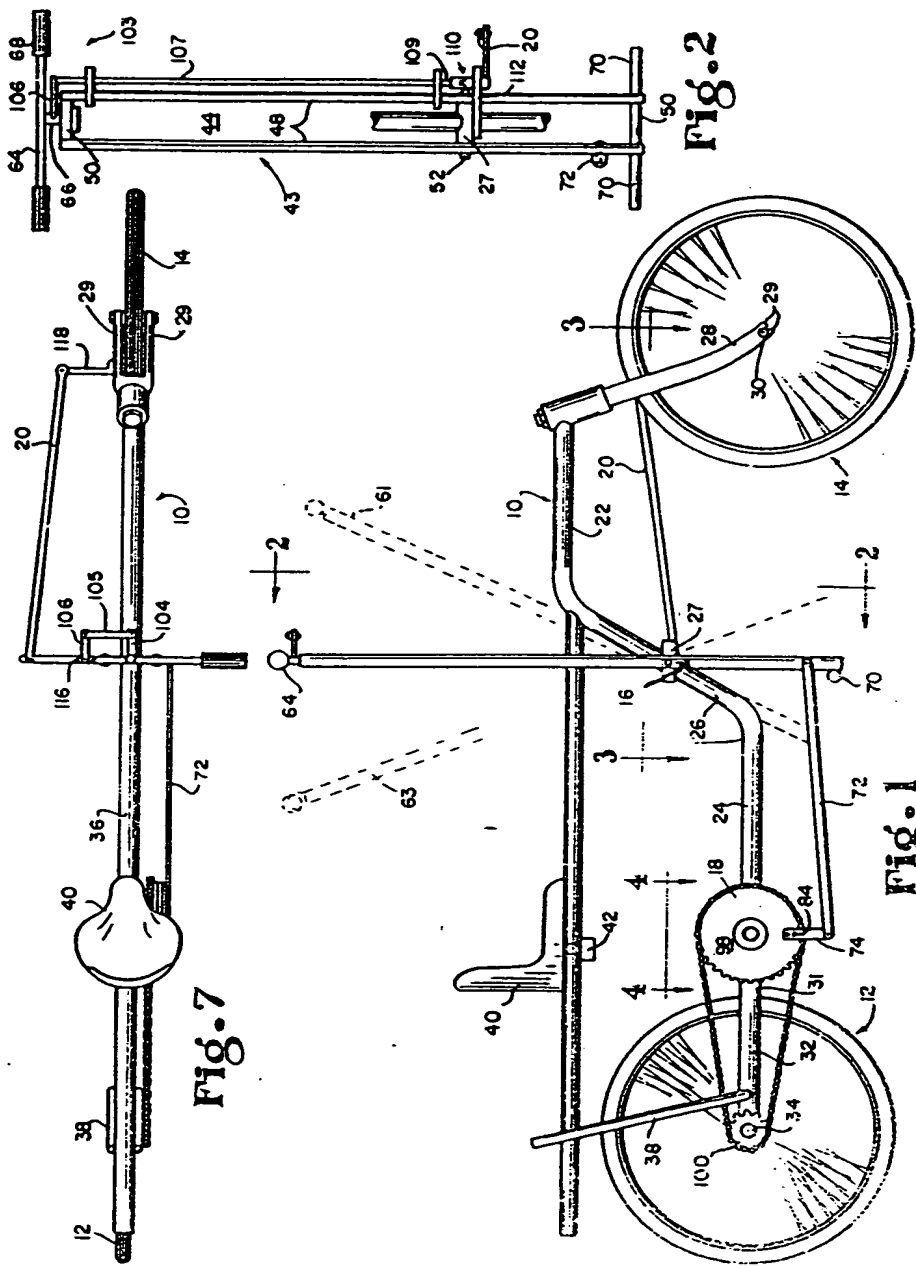

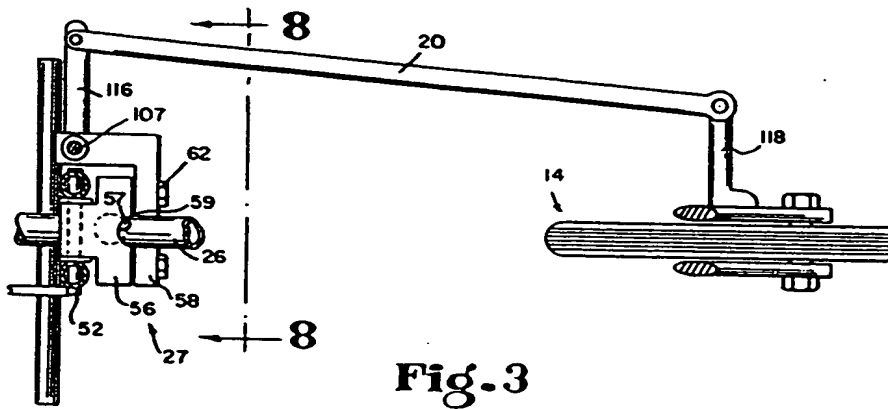

Fig. 3

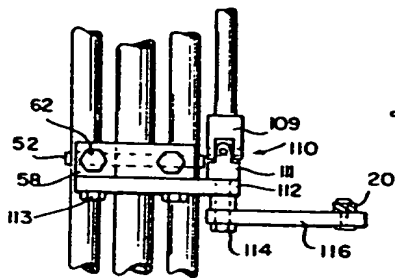

Fig. 8

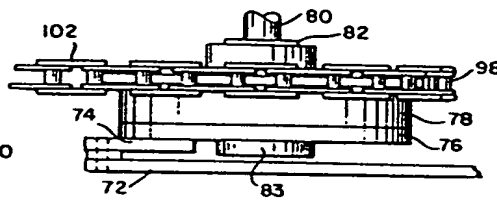

Fig. 4

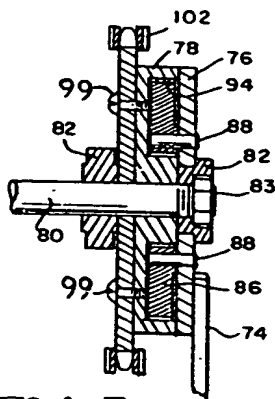

Fig. 5

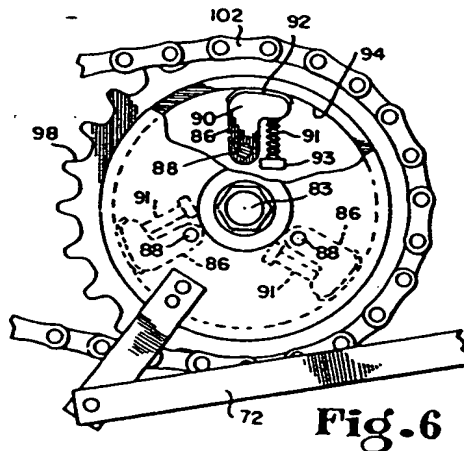

Fig. 6